

Installation and Service Instructions

Universal - Expansion Joint



The following points must be observed during installation:

1. Make sure the expansion joint is the correct size for the installation (where necessary, allow for pre-tensioning)
2. If the expansion joint has an arrow on it, this must point in the direction of flow.
3. During installation and subsequent operation, the expansion joint must under no circumstances be subject to torsion (twisting).
4. The bellows of the expansion joint must be protected with ceramic fibre material (e.g. against sweat, plaster or mortar splashes) and against high mechanical stresses (throwing heavy blows).
5. If present, the yellow marked installation fixing must be removed before putting into service.
6. Do not apply any test pressure until the line has been made immovable at the fixed points and guides.
7. During servicing, check for freedom of movement in the guide bearings. Inspect the bellows for damage, corrosion and cracks, and check that the stroke is within limits. Test the fixed points for rigidity.
8. Testing after changes in operation conditions (e.g. pressure, temperature, medium, flow direction, vibrations, frequency of load fluctuations) and when the existing equipment is extended. In such cases, consultation with us should take place, regarding testing the existing expansion joints for their suitability under the altered conditions.
9. The valid working pressure has to be limited with a suitable safety-feature.

laying of pipe:

Installation of the pipes must be done as to ensure a straight run. The fixed points must be arranged in such a way that only those expansion occur which correspond to the chosen type of expansion joint.

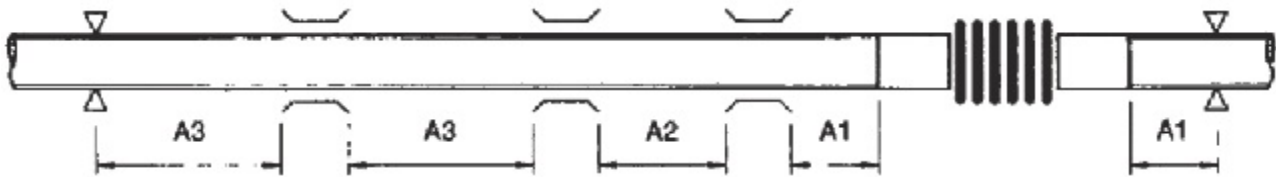

guide bearings have to be put in position as on the sketch above.

guide bearings:

As guide bearings, which protect the pipeline from bending in all directions, plain or roller bearings are preferable. A free-swinging suspension is to be avoided. For pipelines in the open, protection against wind and snow should be provided.

pre-tensioning:

Universal expansion joints are designed as standard for taking up movements in both plus and minus directions. With the appropriate installation, half the movement can be taken up in each direction - e.g. $\pm 20 = 40$ mm. By pre-tensioning the bellows, the full working range of the expansion joint can be exploited.

The following parameters are relevant for calculation of the pre-tensioning:

- | | |
|---|---|
| 1. Installation dimensions at installation temperature | 4. highest actual operating temperature |
| 2. neutral length of the expansion joint without pre-tensioning | 5. lowest actual operating temperature |
| 3. total movement of the expansion joint | 6. installation temperature |

caution: If there are temperatures above 100° C make use of the decreasing factors concerning "pressure" and "movement". (as you can see in the product catalogue, issue 2/2001, page 31-29 or at <http://www.innoflex.at> (installation instructions))

decreasing factors temperature °C	50	100	150	200	250	300	350	400
pressure	0,93	0,86	0,84	0,78	0,75	0,68	0,59	0,54
movement	0,98	0,95	0,93	0,91	0,89	0,87	0,86	0,85

Installation and Service Instructions

Universal - Expansion Joint

examples of pre-tensioning:

$$E = H/2 \cdot H \times t_u/t_d$$

where $t_u = t_e \cdot t_m$ and $t_d = t_{max} \cdot t_{min}$

		example 1	example 2
t_{max}	maximum possible temperature of the pipeline	+ 130°C	+ 50°C
t_{min}	minimum possible temperature of the pipeline	- 10°C	- 10°C
t_e	installation temperature	+ 20°C	+ 20°C
H	calculated total expansion of the pipeline	216 mm	216 mm
	Installation length according to above formular	61 mm	0 mm

pre-tensioning in the direction:

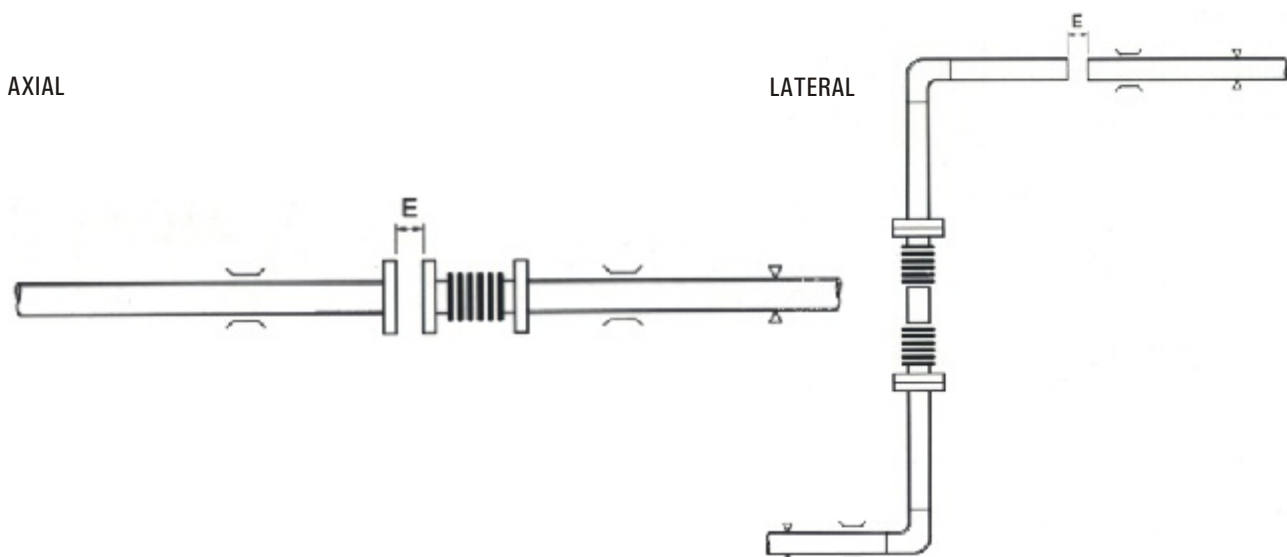

1. Fix the pipeline at both ends.
2. Mount the universal expansion joint in the initial position.
3. Cut out a length of pipe corresponding to the required pre-tensioning E, or mount the pipe line such that the separation of the pipes from one another corresponds to the required pre-tensioning E.
4. Move the universal expansion joint into the pre-tensioned position E. Finally weld the pipes or combine them using a flange.

Fixed points:

The section of pipe in which the expansion joint is installed must be bounded by fixed points. These must take up both the displacement forces of the expansion joint and the frictional resistance of the guide bearing. Fixed points and guides must be laid out so that the expansion joint does not bear the weight of the pipe.

there are the following types of fixed points:

- a) end-fixed point F_e
- b) knee/elbow fixed points F_k
- c) intermediate fixed points F_m

Important: Make sure that the fixed points are really rigid. It must not be possible for the pipeline to move several millimetres before the system actually becomes rigid.

Only one universal expansion joint may be mounted between two fixed points.